



# Optical Networking Architectures For Avionic Applications

Presented at  
**NASA ACAST Workshop 2005**  
Downtown Cleveland, Ohio  
Wednesday, August 17, 2005

By  
**Hung Nguyen**  
NASA Glenn Research Center  
21000 Brookpark Road  
Cleveland, Ohio 44135

Collaborations: University of Dayton, University of Oklahoma, University of Akron.



# Architecture of Optical Communication Configurations Arranged On-Board Aircraft

## Objective:

Development of test-bed platform for demonstration of voice, video, and data transmission from numerous antennas on the aircraft using the fiber optical networking methodology.

## Significant Benefits for implementation of fiber optical NETWORK:

Existing Networking System	RF/Optical Networking System
Immune to Electromagnetic Interference	Immune to EMI No need of EMI back-shells
Increased volume of Cables/Wires	Single fiber for transmission-less space and reduced weight; greater bandwidth
Susceptible to Electrical Spark Influence	Network design flexibility and capacity
	Improved reliability, simplified maintenance
	Reduction in RF emissions from leaky coaxial cable

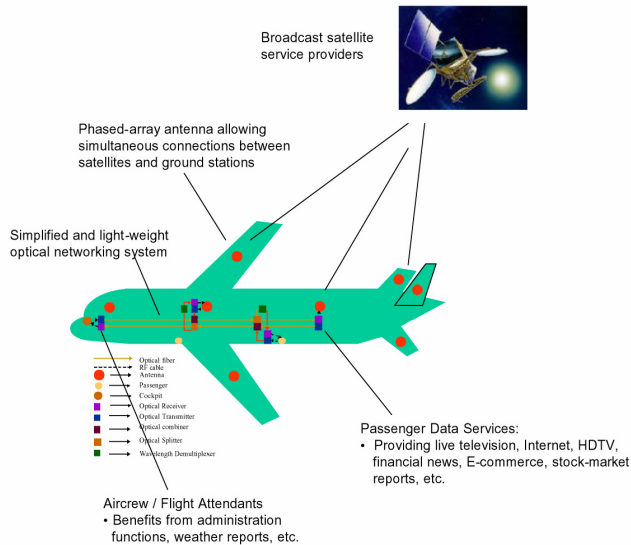
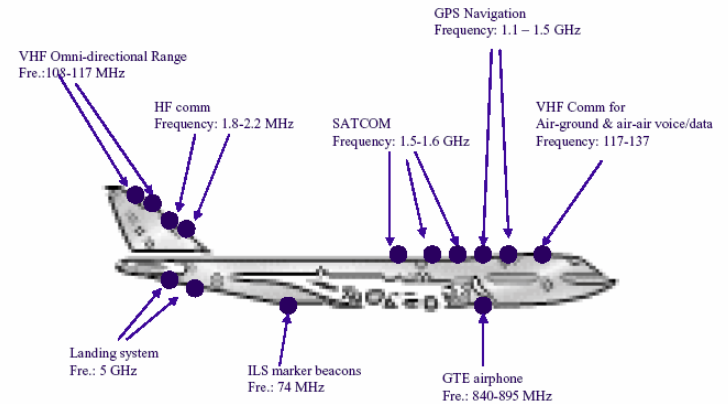

Fiber optic based architecture configuration for On-board applications.



# Architecture Topologies

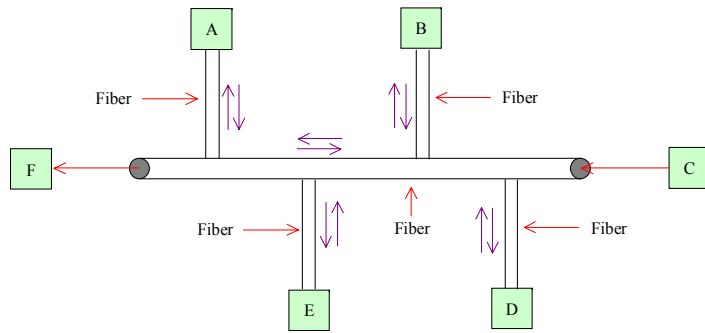

Bus-based Fiber Backbone Using WDM

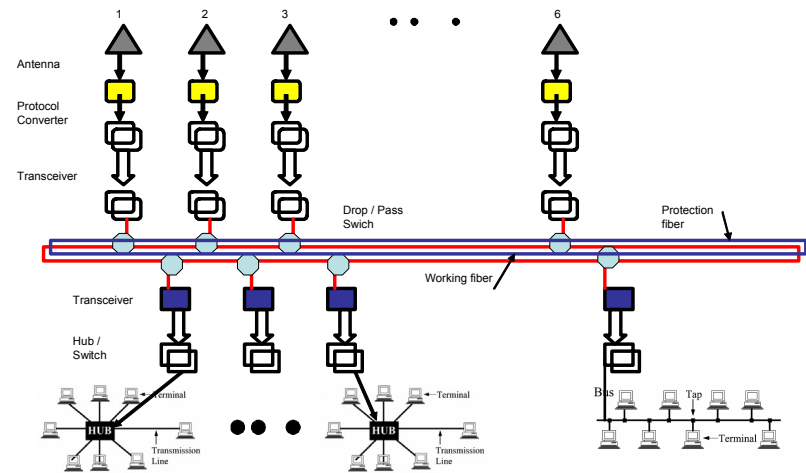
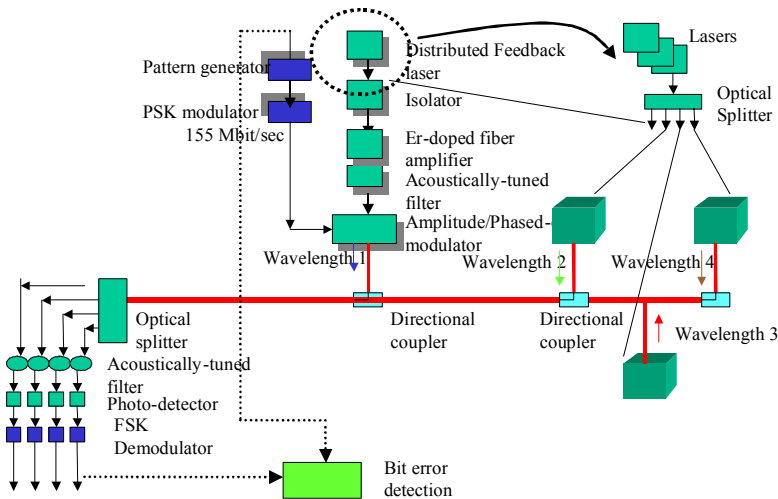
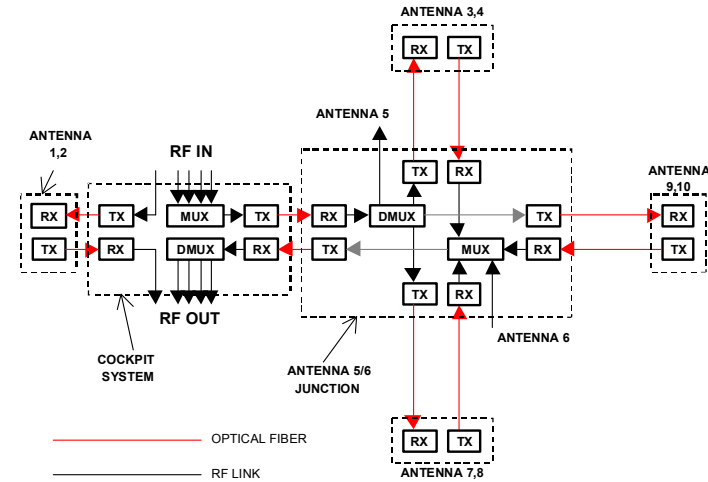

All Optical Ring-Infrastructure Solution Using SONET over Wavelength Division Multiplexing process.



# Experimental Setup

- Optical testing points
- RF Transmission and reflection
- Signal-to-noise ratio
- Signal and video quality test

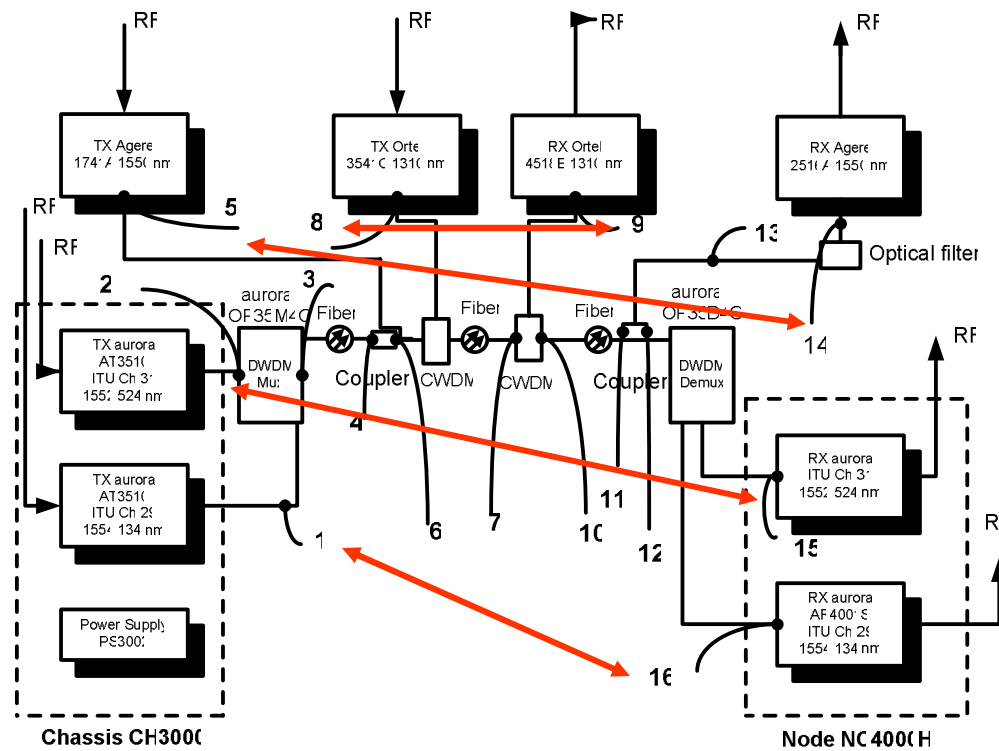



# Requirement of Analog and Digital System

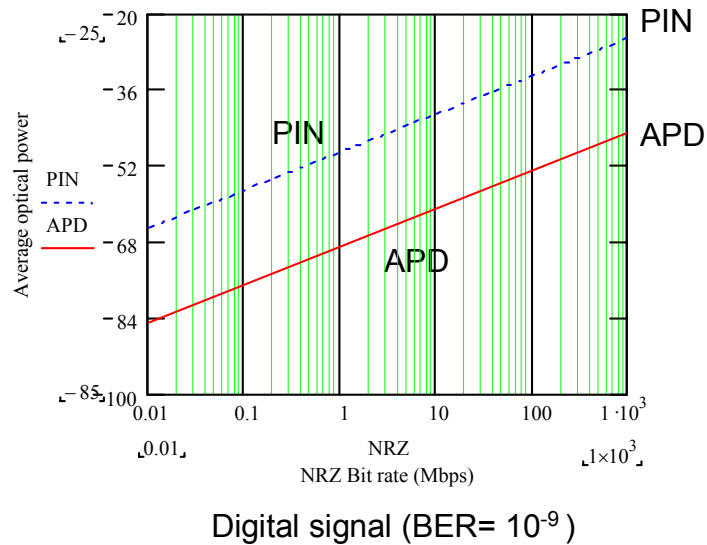

PIN: PIN photodiode (no gain)  
 APD: Avalanche photodiode (internal gain)

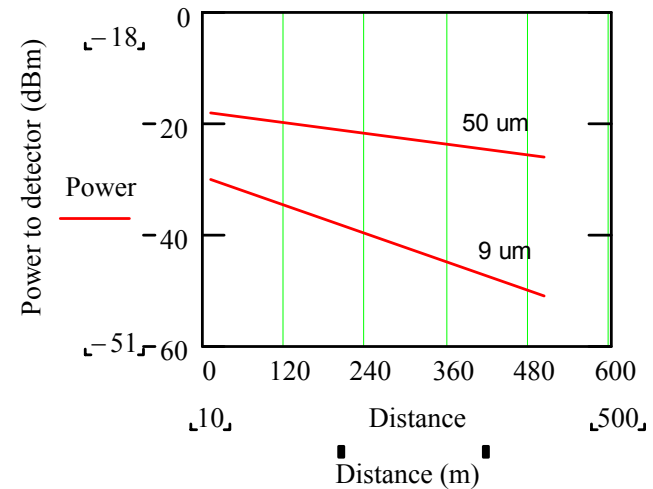

Fiber distance compared for two fiber's size: 50 and 9  $\mu\text{m}$  at 1330 nm wavelength and 500 Mbps.

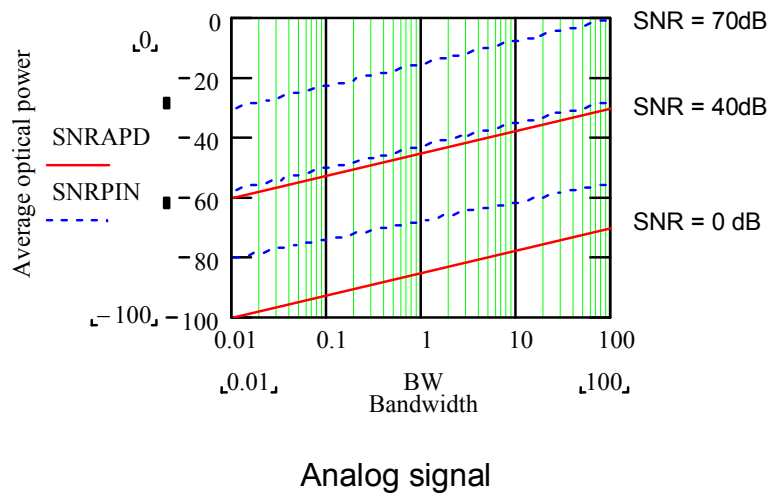



# Experimental Results

Transmitter: Point 1

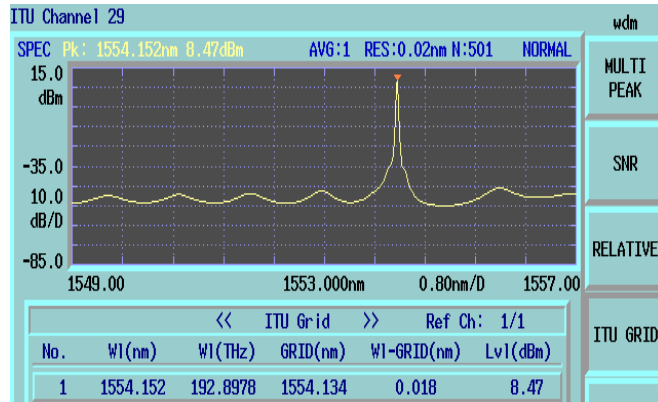

- Wavelength 1554
- The optical output power of transmitter is 8.47 dBm

Receiver: Point 16

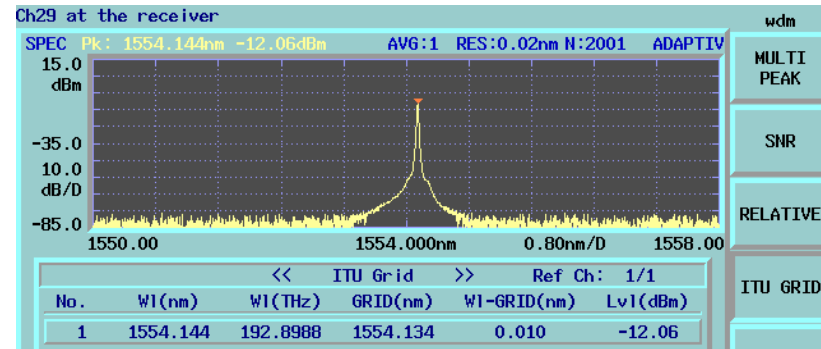

- Wavelength : 1554
- The optical power level of -12.06 dBm is sufficient to allow error free data transmission in this channel.

Transmitter: Point 2

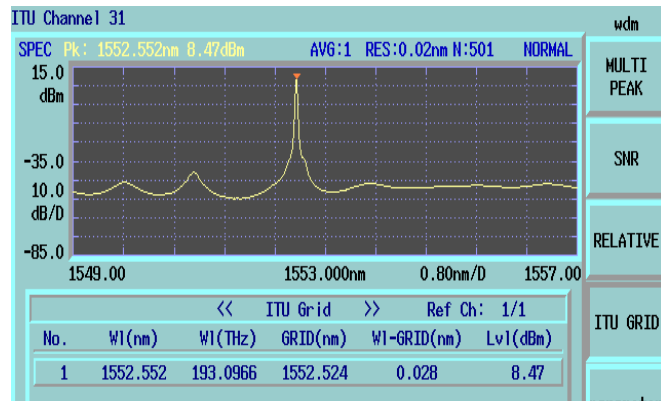

- Wavelength 1552
- The optical output power of transmitter is 8.47 dBm

Receiver: Point 15

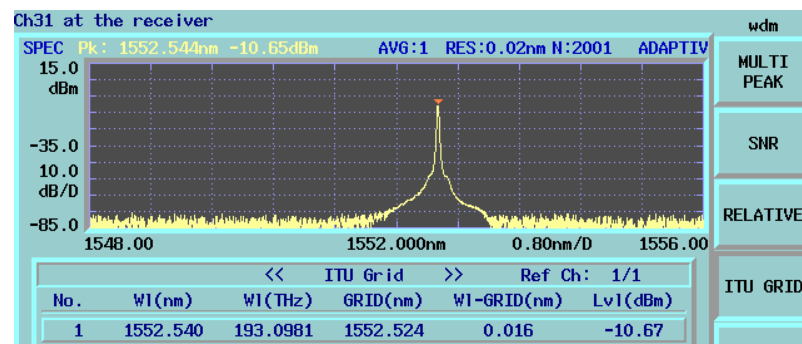

- Wavelength : 1552
- The optical power level of -12.06 dBm is sufficient to allow error free data transmission in this channel.



# Experimental Results

Transmitter: Point 5

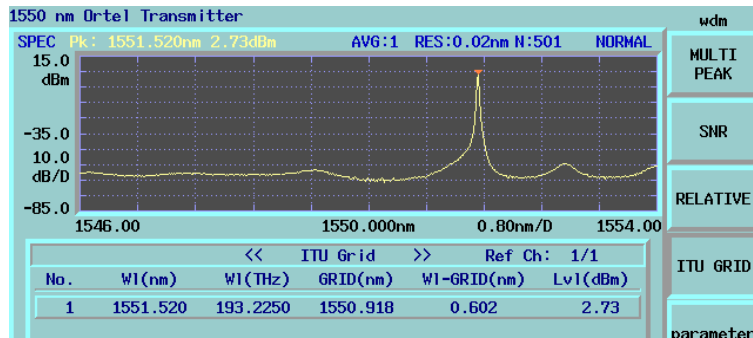

- Wavelength 1551
- The optical output power of transmitter is 2.73 dBm

Receiver: Point 14

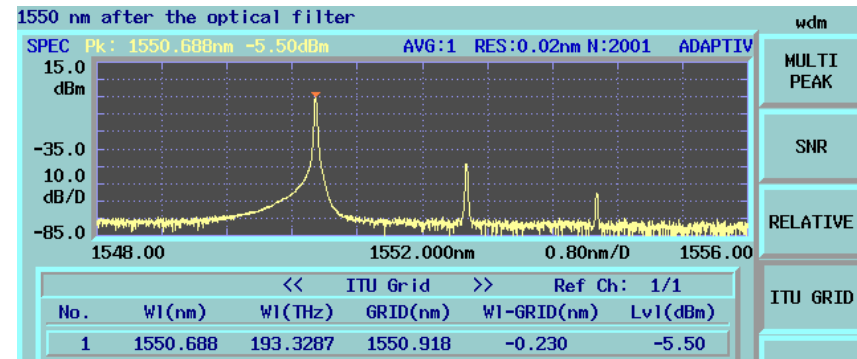

- Wavelength : 1551
- The optical power level of – 5.50 dBm.

Transmitter: Point 8

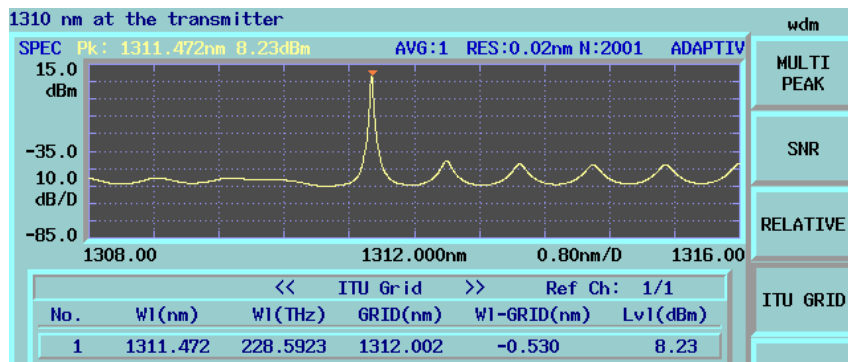

- Wavelength 1331
- The optical output power of transmitter is 8.23 dBm

Receiver: Point 9

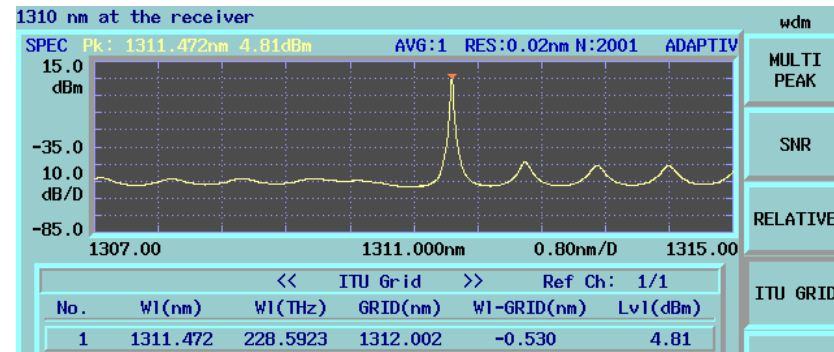

- Wavelength : 1311
- The optical power level of 4.81dBm is sufficient to allow error free data transmission from this channel (well above the receiver sensitivity).



# Experimental Results

Transmitter: Point 1

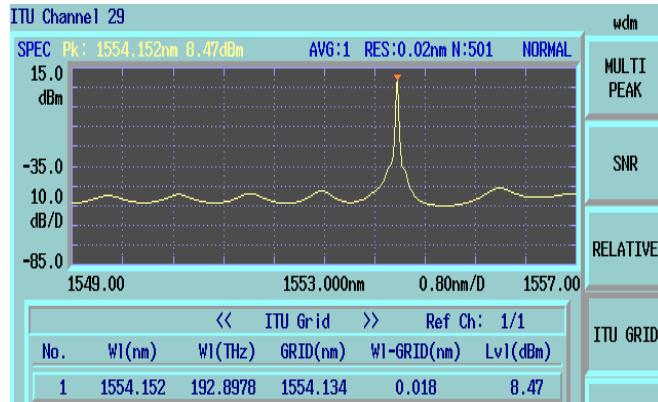

- Wavelength 1554
- The optical output power of transmitter is 8.47 dBm

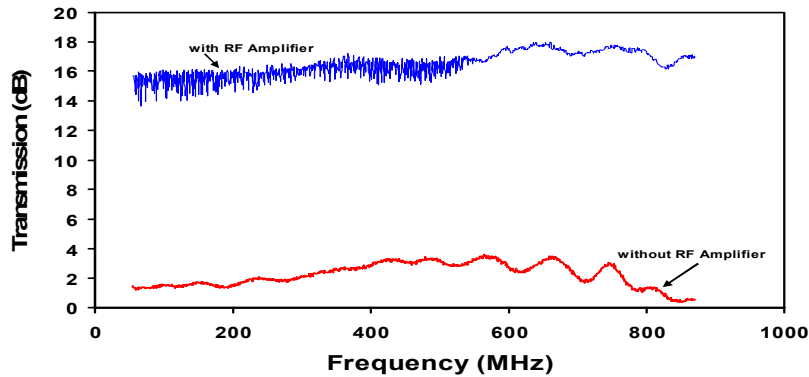

- Transmission response without the RF amplifier varied around 2dB over the frequency range of 55-900 MHz.
- Transmission response with the RF amplifier varied around 16 dB over the same frequency range.

Receiver: Point 16

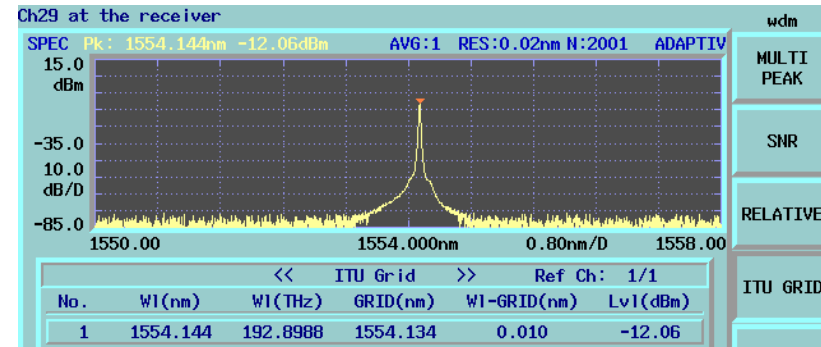

- Wavelength : 1554
- The optical power level of -12.06 dBm is sufficient to allow error free data transmission in this channel.

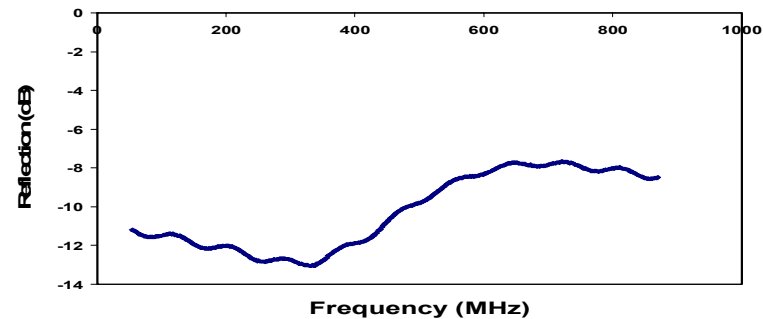

- Reflected power is due to the impedance mismatch between the RF input cable and the transmitter.
- Also, reflected power can be due to the transmitter laser modulation circuitry.
- Reflection response for channel 29 varied around -10 dB over the frequency range 55-900 MHz.





# Experimental Results

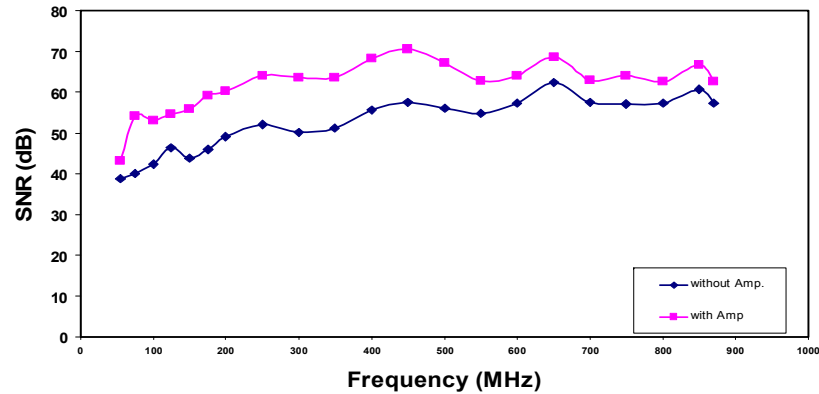

- SNR without the RF amplifier varied between 38.77 dB and 60.69 dB over the frequency range 55-900 MHz.
- SNR with the RF amplifier varied between 43 dB and 68.69 dB over the same frequency range.



# Experimental Results

Transmitter: Point 2

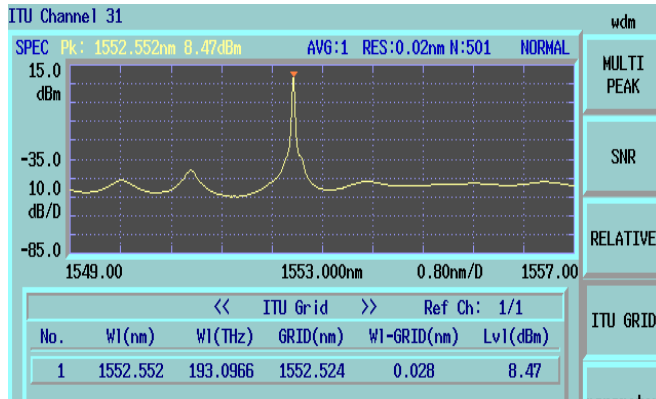

- Wavelength 1552
- The optical power level of transmitter is 8.47 dBm

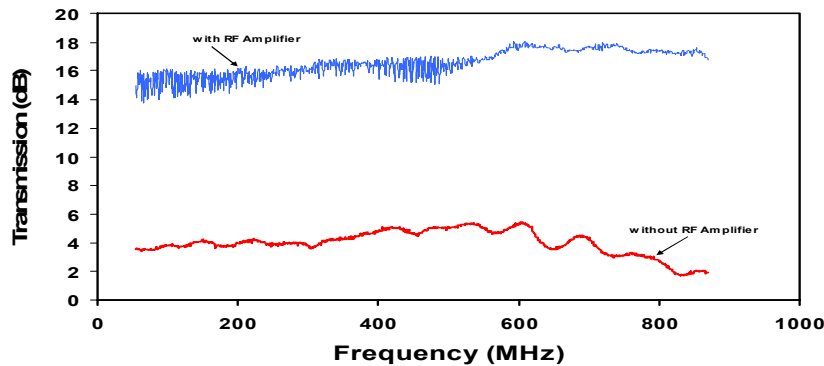

- Transmission response without the RF amplifier is approximately 4 dB over the frequency range 55-900 MHz
- Transmission response with the RF amplifier is approximately 16 dB over the same frequency range.

Receiver: Point 15

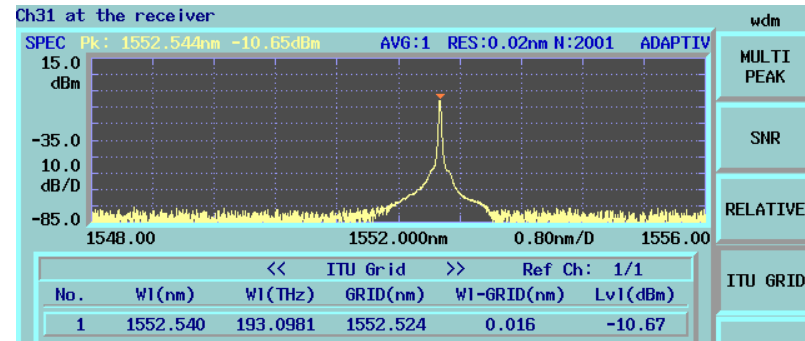

- Wavelength : 1552
- The optical power level of -12.06 dBm is sufficient to allow error free data transmission in this channel.

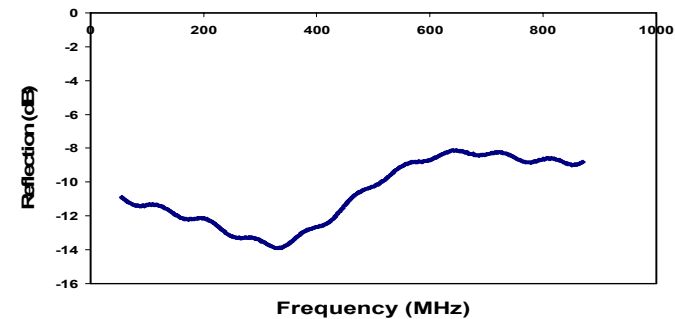

- Reflection response for channel 31 is varied between -8.16 dB to -13.91 dB over the frequency range 55-900 MHz.



# Experimental Results

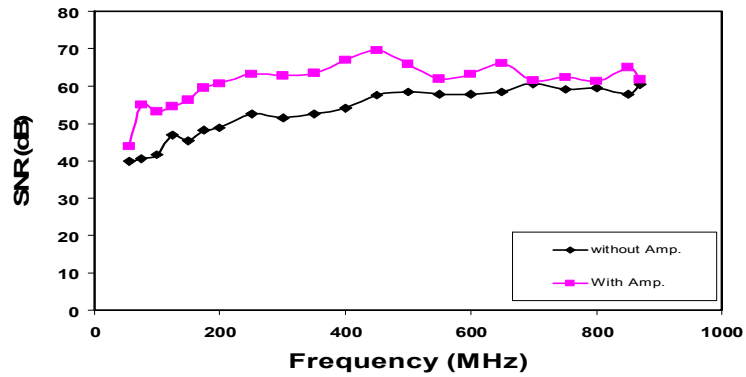

- SNR without the RF amplifier varied between 39.81dB and 60.53 dB over the frequency range 55-900 MHz.
- SNR with the RF amplifier varied between 43.71 dB and 69.51 dB over the same frequency range.



# Signal Quality Test

- Signal Quality measured with the digital oscilloscope
- Input and Output FM measured
- Network Analyzer used to enable analog traffic on the second channel

## Transmitter: Point 1

- Wavelength 1554
- The optical output power of transmitter is 8.47 dBm

## Receiver: Point 16

- Wavelength : 1554
- The optical power level of -12.06 dBm.

## FM modulation

**Carrier: 100 MHz**

**Modulating signal: 1000 Hz**

**Deviation:20 KHz**

■ High signal quality of the FM signal is preserved in the output waveform.

■ Output shows very little distortion, which is numerically measured and presented in the Distortion Test

**FM input for 100MHz**

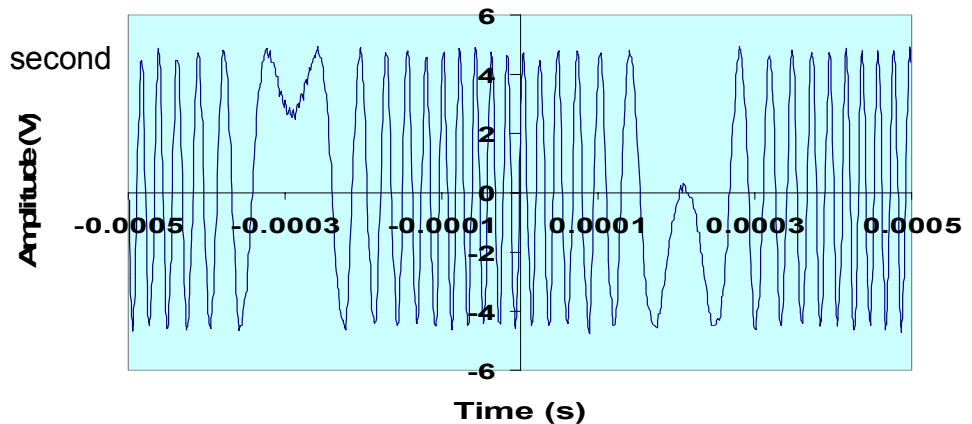

## Receiver: Point 16

- Wavelength : 1554
- The optical power level of -12.06 dBm.

**FM output at 100 MHz**

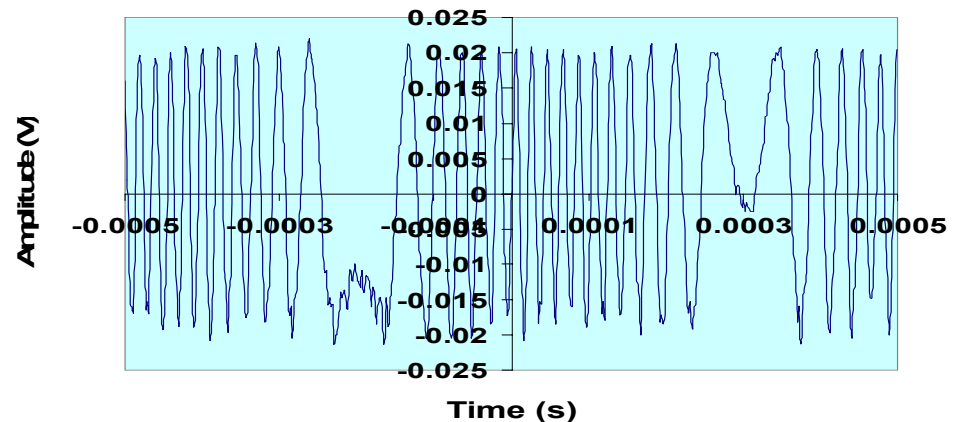



# Video Test

- Video Tester provides a baseband test video signal to the Input path
  - The video signal goes through FDM and is output on a 1554 fiber in the Input path
  - Network Analyzer used as analog traffic on the second channel
  - Output amplification due to input path TX
  - Almost no distortion in the output waveform
- Cross correlation of the input and output  
xcorr=.9984

Input for Multiburst Test Video Signal

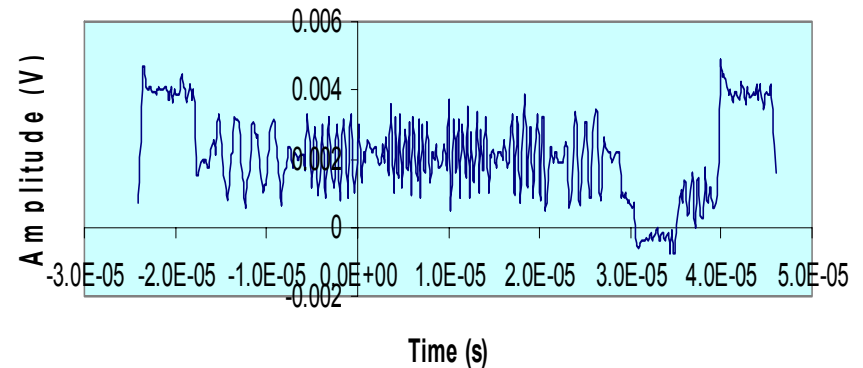

Output for Multiburst Video Test Signal

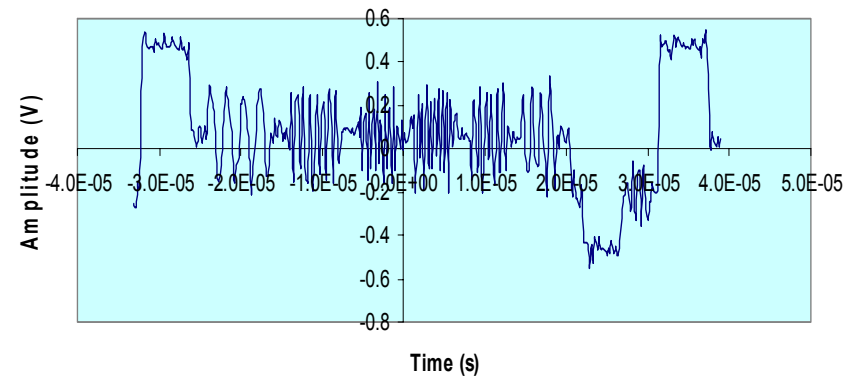

Input



Output

- Camera snapshot input and output show identical quality
- No distortion in the output picture



# SONET over Optical Wavelength Division Multiplexing (WDM) Approach

## Ring Protection Path Scenario

Methods of multiplexing different network data into a single transport stream.

- SONET/SDH time division multiplexing system

### WDM system

- Different wavelengths support different “electrical” multiplexing services.

- Each time a wavelength is dropped at a node, a SONET Add/drop module is needed to process the dropped wavelength.
- The use of dual links for fast failover and backup.
- Protection and restoration data paths to prevent data loss due to cable failure, port failure, or catastrophic failures.

RING REDUNDANCY AND PROTECTION NETWORKING ARCHITECTURE

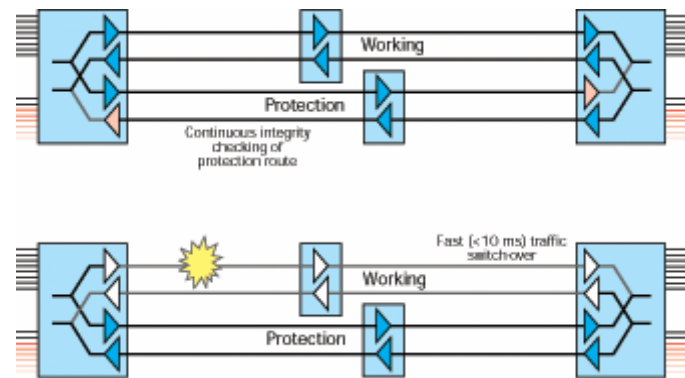
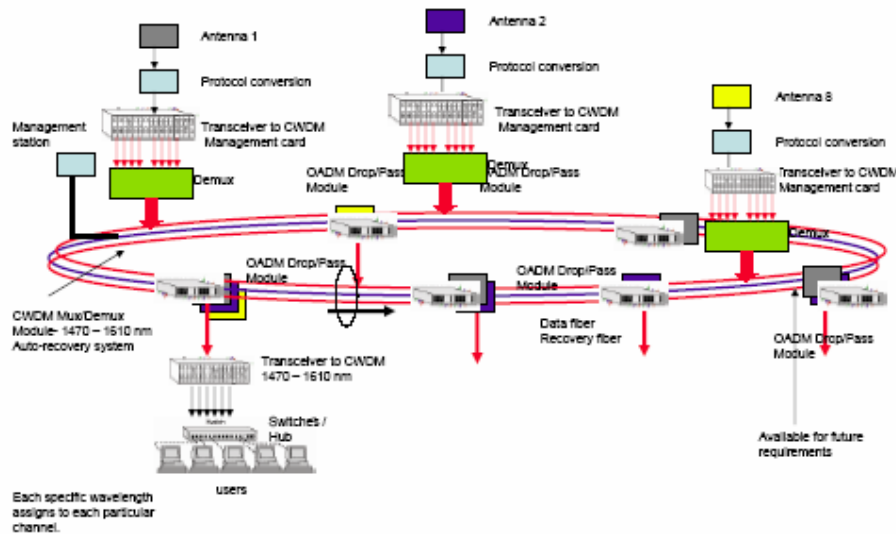



**Thank You for Your Attention**